



# Digital Series DS50

In this documentation you will find information about:

- Excellent sonic performance class-D design
- Flat, fully load-independent frequency response
- Mono block, switched mode power supplies
- Dynamic Damping Control
- Active Clip Eliminator
- 64-bits 96kHz digital processing
- Aluminum Reinforced Molest Resistant chassis
- Road(y) proof
- Technical specifications

## Excellent sonic performance class-D design

High power and very pure signal amplification under heavy user conditions were the main goals in the development of the DS Series amplifier range. These (mono block) power amplifiers are built with an excellent sonic performing class-D design for increased efficiency by decreased weight and dissipation. With an output power exceeding 1600W @ 8Ω per channel, a S/N ratio of more than 110dB and a THD percentage of < 0.007% @ 1kHz (100W, 8Ω). The DS50 combines (sound)quality, power and very low weight into one unit. Each audio channel has its own power supply. The SA digital amps are among the best sounding digital amps on the pro-audio market!

## Dynamic Damping Control

An important feature is Stage Accompany's Dynamic Damping Control (DDC™) system, with which a very high damping factor is being realized (10.000 @ 1kHz). The result is even more remarkable in combination with a Stage Accompany "DDC prewired" loudspeaker system. This unique circuit compensates for the cable and connector resistance, which can be enormous when long loudspeaker cables are being used (lengths sometimes exceeding 50 meters, 164 feet). The result is an extremely tight and accurate bass and mid response, in combination with a "DDC-prewired" loudspeaker system. Furthermore, with "DDC™" both linear and non-linear distortion are reduced substantially. The amps can also be used on a normal, not DDC-prewired, loudspeaker.

## Active Clip Eliminator

Also built into the DS50 is our Active Clip Eliminator (ACE™), a circuit which constantly monitors all outputs of the amplifier for continued clipping. When clipping is detected, the related input is inaudible reduced to the safest maximum level in order to prevent harmonics from damaging the high frequency drivers, to maintain the amplifier's sonic quality and to prevent thermal shutdown.

## 64-bit 96kHz digital processing

Controlled by a very high quality 64-bit DSP unit the DS50 has all the necessary features of a modern professional amplifier to process input from the analog and digital domain. The internal DSP unit provides the following functions: SA speaker dedicated presets, compressor, limiter and delay, up to 10 parametric filters on each in- and output, up to 24dB/Oct. Bessel / Butterworth / Linkwitz-Riley crossovers, max. 1s delay on each input, max. 40ms delay on each output, full configuration and real time monitoring via PC over Ethernet (10/100Base-TX, IP addressing through DHCP or APIPA) or USB interface. The Stage Control software, to remote control the DS50, is available for MS Windows (32-bit and 64-bit) and Mac OS X.

## Aluminum Reinforced Molest Resistant chassis

As base, the well-known Stage Accompany ARMoR™ chassis is used, made from 3mm thick ("mill-spec") aluminum. Indestructible, absolute torsion free, best strength to weight ratio in the industry, improved heat dispersion and a high radiation shielding are the characteristics of this chassis.

## Road(y) proof

The amp is equipped with "Soft start" circuit, variable fan speed, ground lift and LED indicator "power", "signal", "clip". Specific readouts about output power, level, limiting and others will be showed at the 2.5" front panel display. The amp is protected against high temperature, DC on output, short circuit and HF on input.

## Wiring for DDC™

For absolute top quality sound reproduction, the DS50 is equipped with dynamic Damping Control™. The DDC™ system is based on 2 loudspeaker wires that return from the speaker to the (SA) amplifier. The picture below shows the wiring of SpeakON NL4 connector in combination with the DDC™ system.

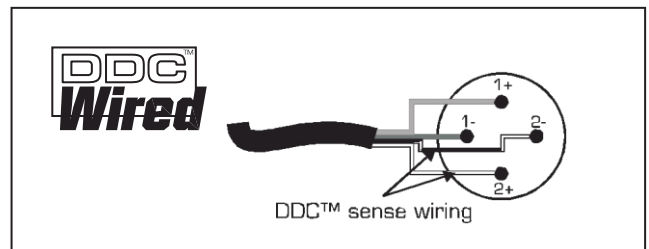

## Front and rear view of the DS50

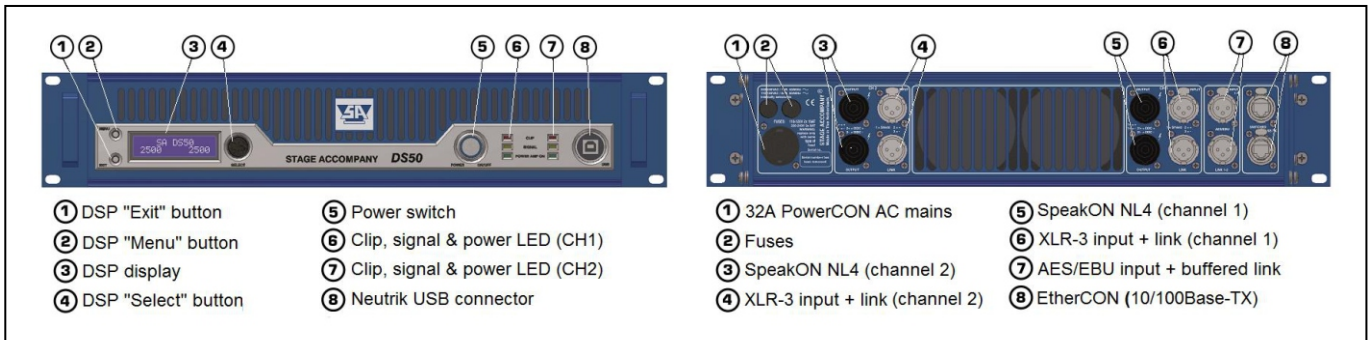

## Stage Control software

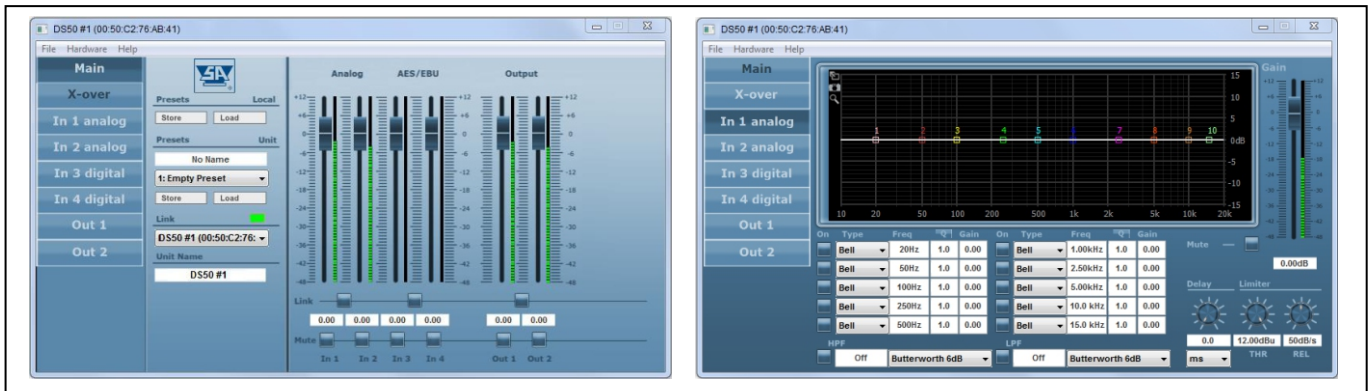

## Technical specifications

Efficiency	: 92% @ full power
Max input level	: +23dBu
Input impedance	: 25kΩ
Frequency range (@ 100W into 8Ω)	: 10Hz – 40kHz
Gain	: 33dB
Channel separation	: > 90dB @ 1kHz
Total harmonic distortion	: 0.05% 20Hz – 20kHz, Pout < Pmax/2 0.05% 20Hz – 20kHz, Pout = 1W amplifier section
Output noise	: 30uV unweighted, 20Hz – 20kHz
Damping factor	: 10.000 @ 1kHz, 8Ω
Output power (@ 1kHz, < 1% THD)	: 2 x 1600W @ 8Ω
Amplifier section	: flat load-independent frequency response
Audio, data & mains connections	: 1 x Neutrik USB connector (located at the front) 2 x XLR-3 female connector for input signal 2 x XLR-3 male connector for signal link 4 x SpeakON NL4 for output signal 1 x 32A PowerCON connector for mains power 2 x EtherCON connector (switched 10/100/Base-TX, can be stacked up to 24 units) 2 x XLR-3 AES/EBU connector for input and buffered out
DSP section	: up to 10 parametric filters on each input and each output Butterworth, Bessel, Linkwitz-Riley filters up to 24dB/oct. compressor, delay and limiter on each input and each output
Mains supply voltage	: stated at the rear of amplifier
Power consumption	: 3500VA
Housing	: 19" Rack Mount, 2HU high, 415mm deep
Weight	: 12.5kg (27.3lb)
Warranty	: 3 years



Stage Accompany bv  
 Haven 28  
 2984 BR Ridderkerk  
 The Netherlands  
 Tel: 31 (0)180 426225  
 Fax: 31 (0)180 421831  
 E-mail: info@StageAccompany.com

Copyright 2013 Stage Accompany bv.  
 The information in this document is continually being developed. Whilst every effort has been made to make it as accurate as possible, no warranty of accuracy is made or implied by the makers. Stage accompany shall have neither liability, nor responsibility to any person or entity with the respect to loss or damages in connection with or arising from the information contained in this document

***That's How Music Should Sound!***